

EVERY
ALTERNATIVE.

Next Generation Natural Gas Engine

2007

ISL G

Dave Lynch

Cummins Westport Inc.

Consider a lower cost alternative

- **Cleanest Available – Meets 2010**
- **Domestic Fuel**
- **Renewable Fuel – LFG to CNG/LNG**
- **Pathway to Hydrogen**

The Two Key Emission Technologies for 2007 ISL G Natural Gas Engines

- **Cooled Exhaust Gas Recirculation (CEGR)**
- **Three Way Catalyst (TWC)**

Cummins

**Cummins
Emissions Solutions**

Introducing Next Generation 2007 Natural Gas Engine Technology



- **ISL G will meet 2010 emissions standards ahead of schedule (0.2 g/bhp-hr NOx, 0.01 g/bhp-hr PM)**
- **85% lower NOx than C Gas Plus**
- **34% more torque at idle**
- **Improved efficiency=improved fuel economy**
- **No exhaust related maintenance costs**

**EVERY
ALTERNATIVE.**

Next Generation Natural Gas Technology Stoichiometric Featuring Cooled EGR

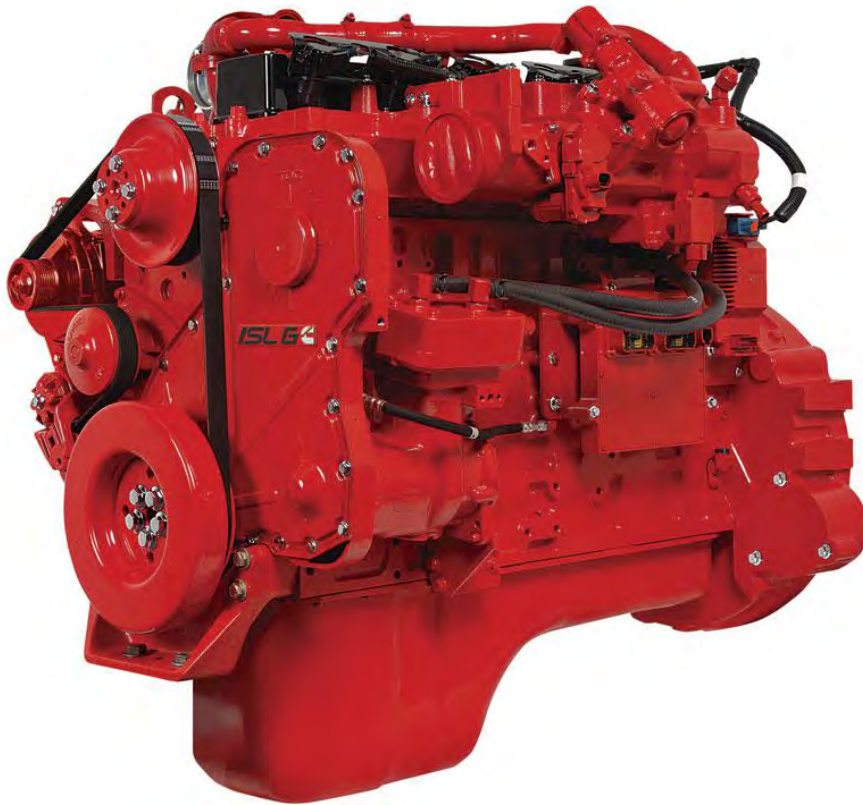

ISL G

**EVERY
ALTERNATIVE.**

Lowest emissions with use of
simple passive TWC
Higher efficiency with combustion
enhancements
8.9 litre stoichiometric EGR engine
with ratings 250- 320 hp

Improved clutch engagement torque
Higher efficiency/improved fuel
economy
Reliability/Durability
Cummins diesel parts

*0.2 NOx in 2007
vs. 1.2 Phase in
Provision*

2007 ISL G Ratings

Rating Matching Example

<u>Peak Power</u>	<u>Peak Torque</u>	<u>Transmission Match</u>	<u>Application</u>
320 @ 2000	1000 @ 1300	Allison B500	Urban Bus
		Allison 4500RDS	Truck
300 @ 2100	860 @ 1300	Allison 3500 RDS	Truck
280 @ 2000	900 @ 1300	Allison B400	Urban Bus
			School Bus
260 @ 2200	660 @ 1300	Allison 3500 RDS	Sweeper
			Yard Spotter
250 @ 2200	730 @ 1300	Allison B300	Shuttle Bus
			School Bus

*Note: ISL G **260/250** will be available Jan 2008*

ISL G rated speed is the same as ISL diesel, eliminating the need to review and adjust final drive ratios

What is changing?

- **Higher vehicle pricing for new technology**
- **Higher cost of Ultra Low Sulfur diesel fuel**
- **SCR for 2010**
- **The shifting economics of diesel operation**

Key Characteristics-Diesel vs. NG



Natural Gas Engines Continuous Improvement

	L 10 G	C 8.3	C Plus	'07 Gas
Emissions	Better	Better	Better	Better
Reliability	Worse	Worse	Similar	Similar
Fuel Cost/Mile	Worse	Worse	Similar	Better
Durability	Worse	Worse	Similar	Similar
LCC	Worse	Worse	Worse	Better
Timeline	1989	1996	2001	2007

EVERY
ALTERNATIVE.

Consider the Natural Gas Alternative

- **Things have changed**
- **Natural gas not for everyone**
- **Natural gas as the lower cost alternative**

Conclusions

- **The economics of vehicle operations are shifting**
- **Energy/Highway Bill funding makes Natural Gas a Bargain.**
- **Some businesses will profit from the opportunity.**

EVERY
ALTERNATIVE.

Change is Inevitable

**“except from a vending
machine”**

2007 Emissions Update Westport

EVERY *** Aftertreatment strategy**
ALTERNATIVE.

* Regeneration explained

* Product improvements

* DPF warning simulator

EVERY
TIME.

Cummins 07 Solution =

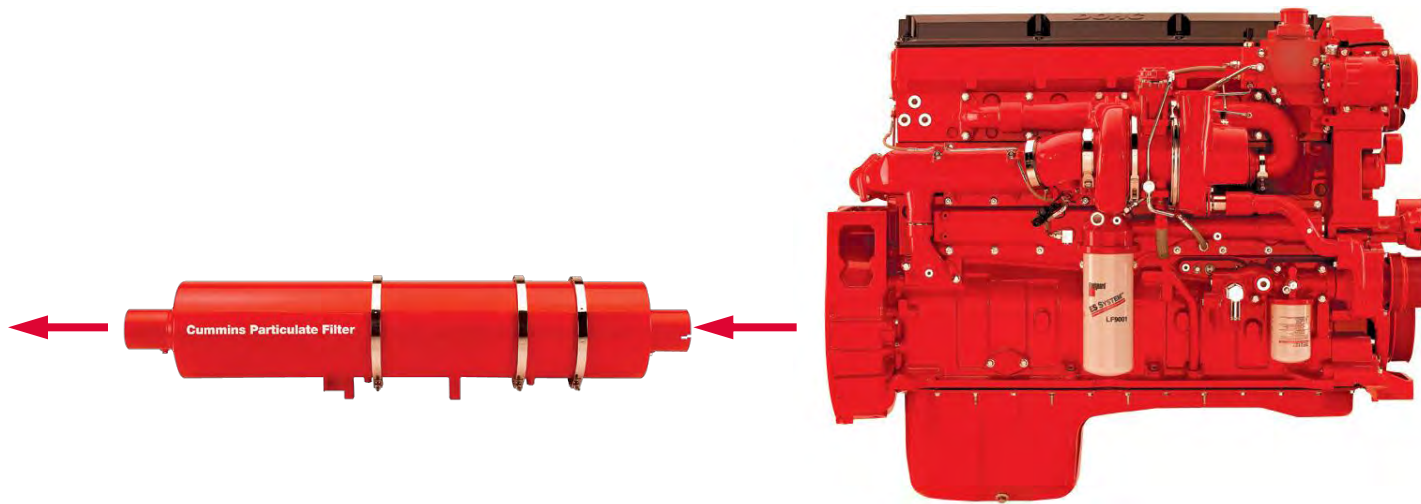

Exhaust Aftertreatment + Optimized 02 EGR Approach

Heavy-Duty 2007 Product(s)

- **Product platforms with stable architecture**
ISX, ISM, ISL, ISC, ISB
- **Common emissions solution for MR & HD**
- **Crankcase ventilation system all engines**
- **Fully integrated Cummins Particulate Filter**
- **Performance: enhanced vs. 2006 EPA**
- **Service intervals: unchanged vs. 2006 EPA**

Crankcase Ventilation

- **Required for 2007 EPA emissions compliance**
- **Cummins-Fleetguard® Enviroguard™ coalescing filter**
- **Simple, high efficiency, serviceable**
- **Change interval depends on engine platform**



Fleetguard®



**EVERY
ALTERNATIVE.**

Cummins Particulate Filter

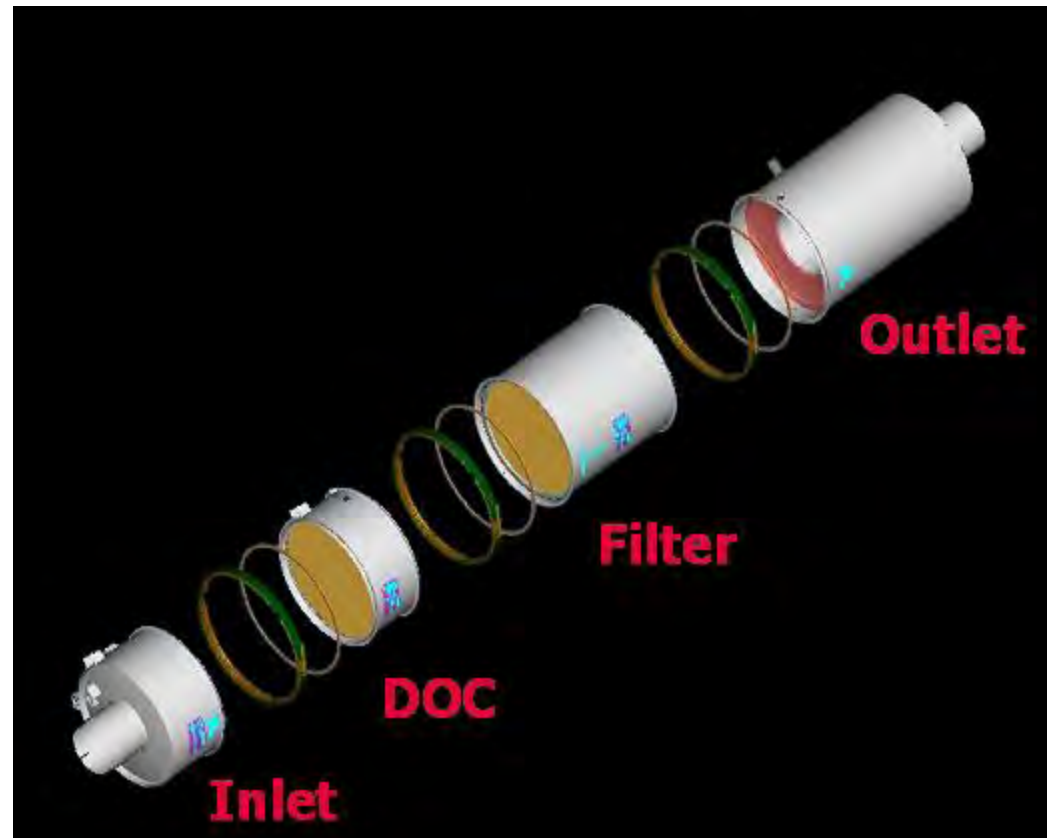

How The Cummins Particulate

- **Critical role of Diesel Oxidation Catalyst**

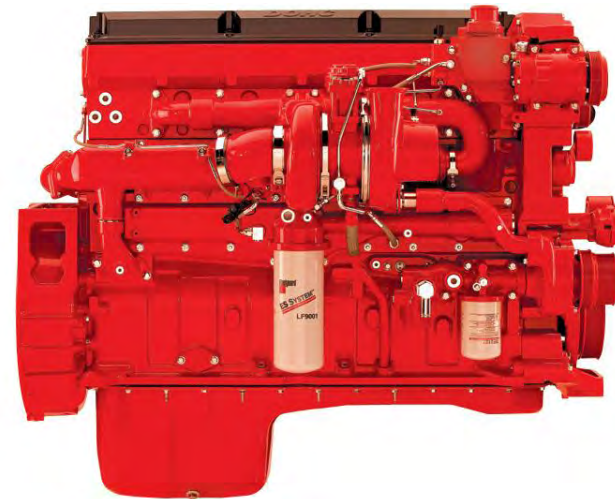
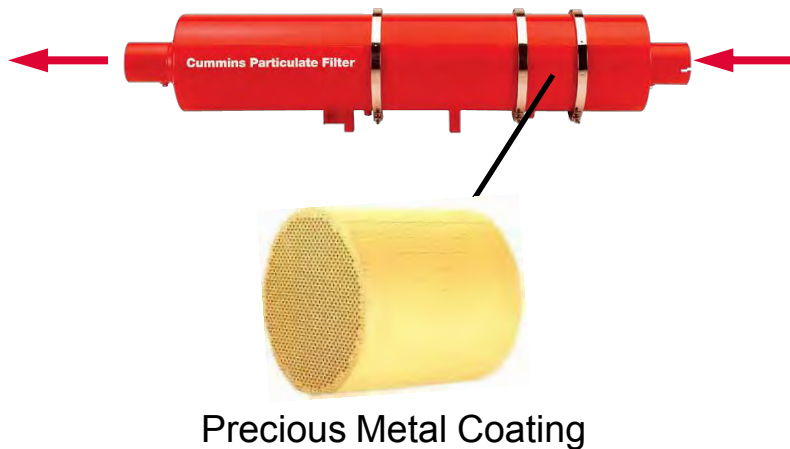

Diesel Oxidation Catalyst

1. Oxidize NO to NO_2 – NO_2 is critical for **Passive Regeneration**
2. Oxidize dosed fuel to produce heat for **Active Regeneration**

How The Cummins Particulate

- PM filter components

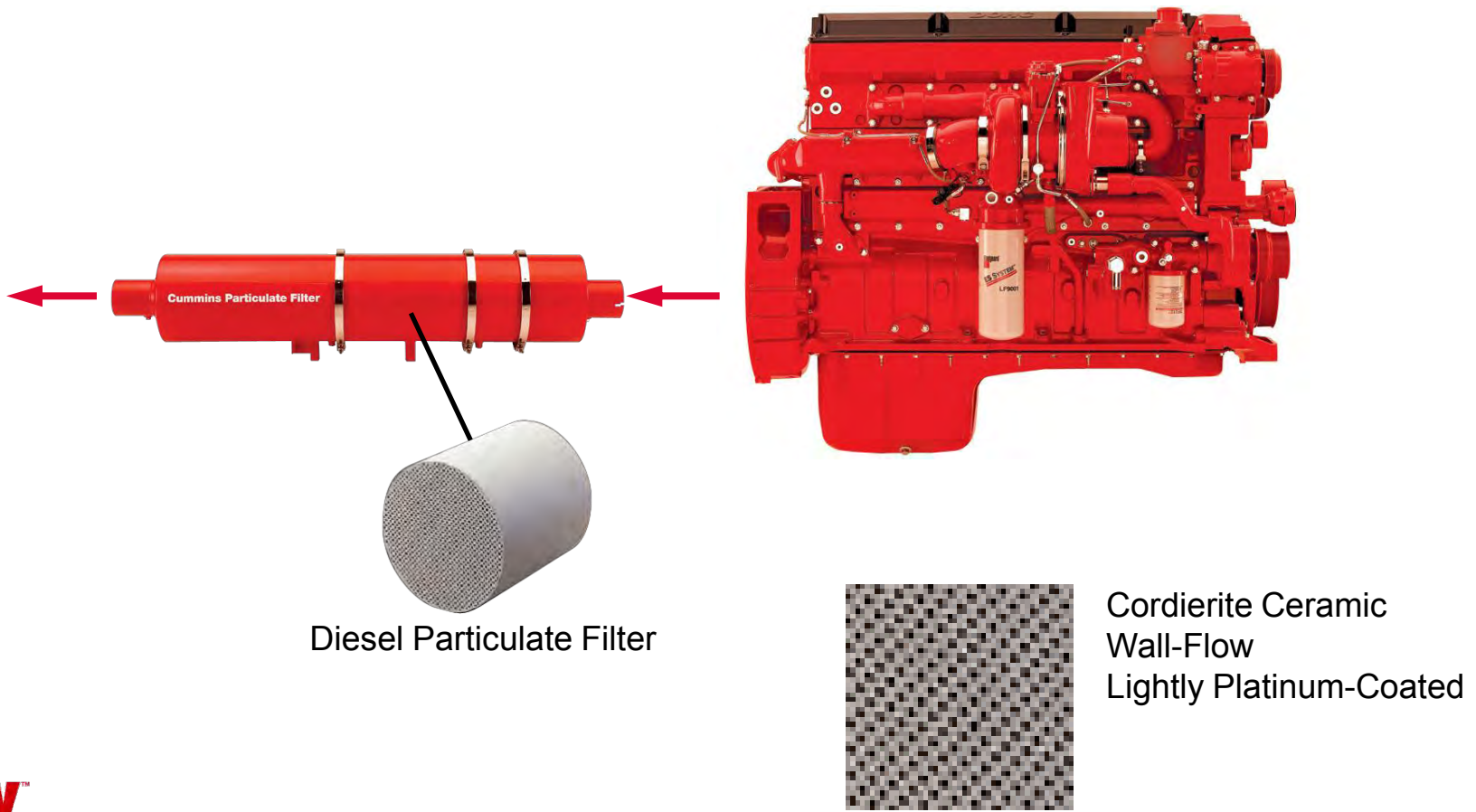

How The Cummins Particulate

- The PM filter removes soot particles from the exhaust by passing the exhaust gases through a ceramic wall-flow filter
- Soot is cleaned through regeneration

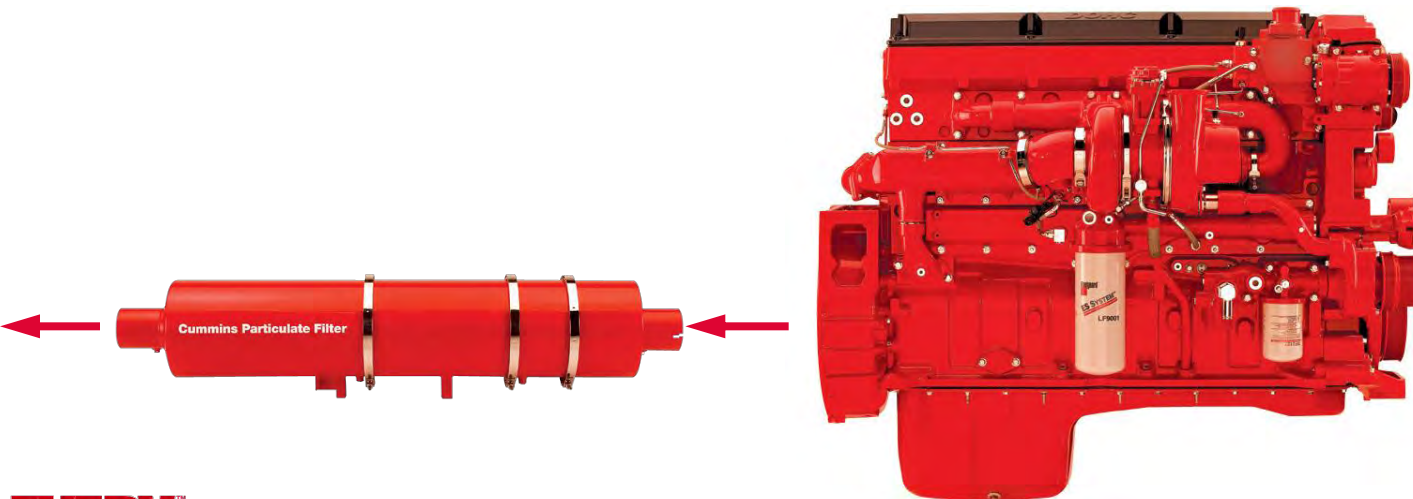
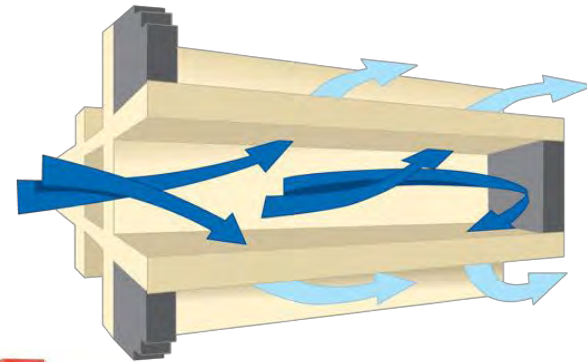

How Active Regeneration Occurs...

- If the application is not generating enough exhaust heat to cause passive regeneration, the ECM applies fuel (HC)

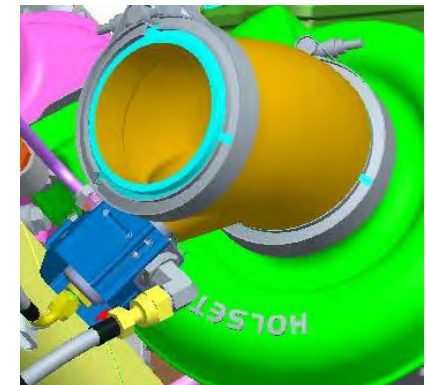
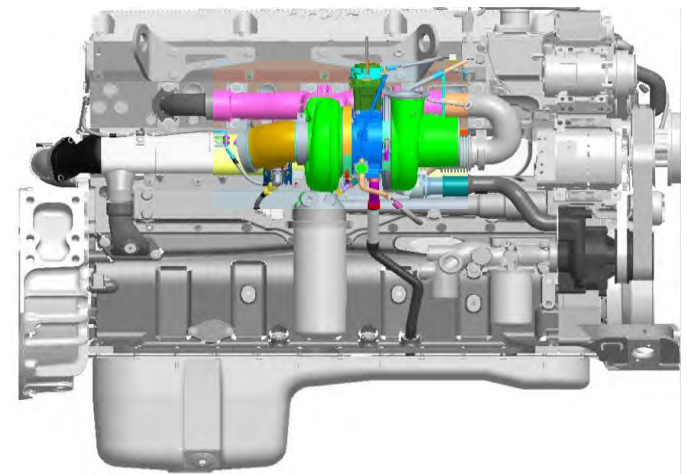

- Fuel Dosing Injector
 - Used to inject fuel into the exhaust during an Active Regeneration
- MidRange
 - HPCR is capable of fulfilling this function

What Is Ash ?

- **Incombustible material that can only be removed by cleaning**
- **Oil additive elements are collected by the filter**
 - Calcium, sulfur, zinc and phosphorous compounds
 - Ca, S, Zn and P
 - CaSO_4 , calcium sulfonate as anhydrite (60%)
 - $\text{Zn}_2\text{P}_2\text{O}_7$, zinc pyrophosphate (20%)

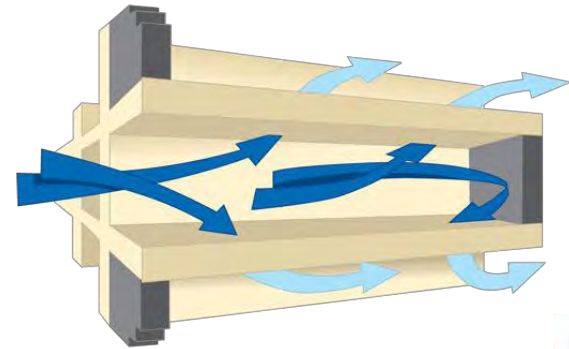
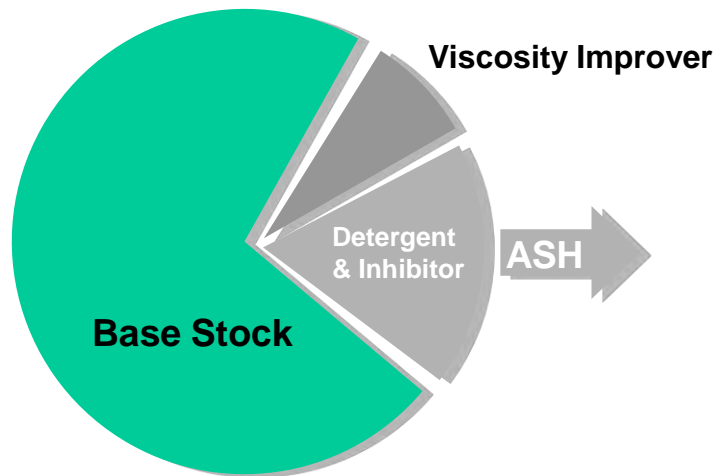

Ash Removal

- **Cleaning intervals are being finalized**
- **Will depend on a number of factors**
 - Duty cycle – light / heavy
 - Condition of the engine – oil consumption
 - Low ash oil (CJ-4)
- **Expect between 200,000 and 400,000 miles
(320,000-640,000 km)**

Particulate Filter

- **Easy operation**
- **Removes ash in less than 30 minutes**
- **Can clean all DPF makes**
- **Available late 2006 at Cummins distributors, dealers and/or customers**



EVERY
ALTERNATIVE.

2007 Product Update

A scenic landscape photograph of a mountain range with snow-capped peaks and green valleys under a blue sky with scattered clouds.

Higher Efficiency EGR Cooler

- **Manage recirculated exhaust gas**
 - Reduce engine temperatures
 - Maintain fuel efficiency
- **EGR Cooler & Plumbing**
 - larger coolant supply and return tubes

EGR Cooler

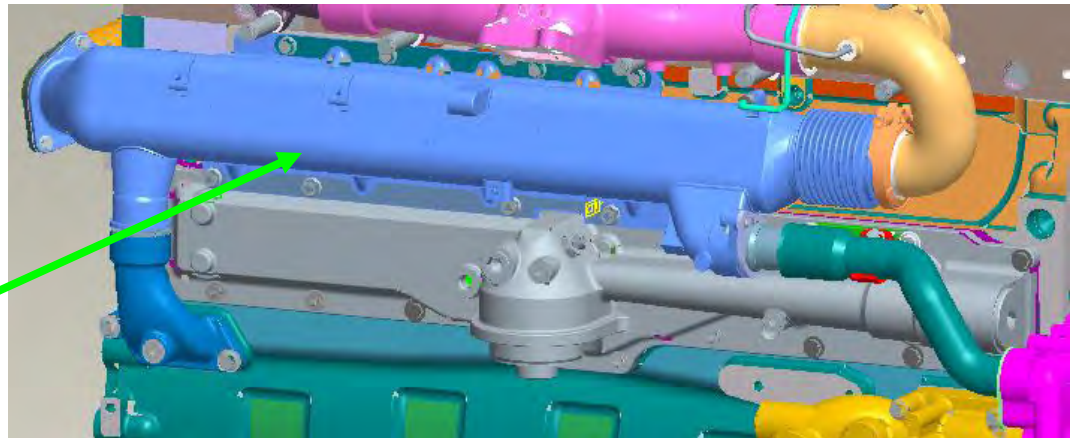

2007 New ECP Valve

- Repositioned to cold side of engine for less heat related stress
- New Dual poppet requires less effort to open & close
- Uses J1939 data link for diagnostics & control
- Easy to replace actuator motor

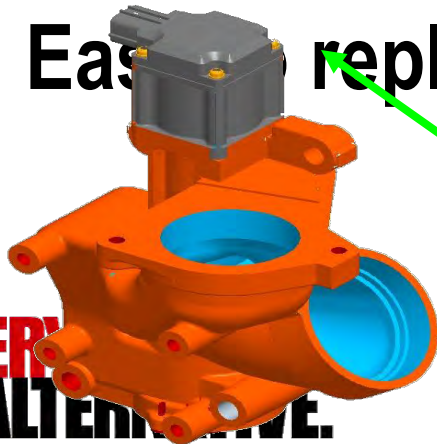

Electric Actuator Motor

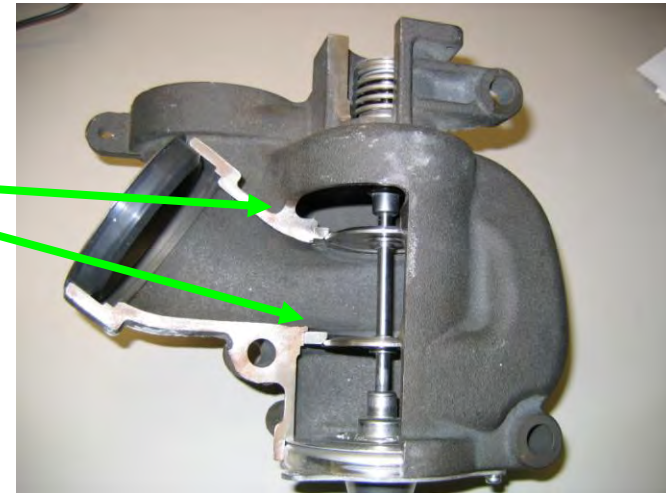

DEPEND ON CUMMINS



Simulato

<i>Situation</i>	<i>Dash Lamps</i>	<i>Operator Action</i>
Normal Operation Passive Regeneration	No Lamps On	Drive Normally



DPF Loading

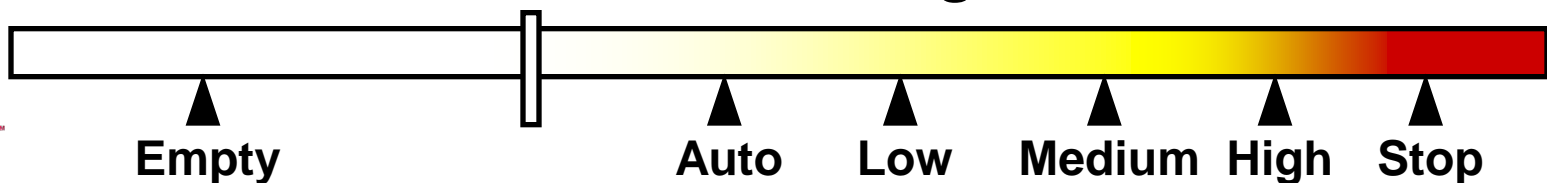

Normal with

<i>Situation</i>	<i>Dash Lamps</i>	<i>Operator Action</i>
Normal Operation Passive Regeneration	None	None



DPF Loading

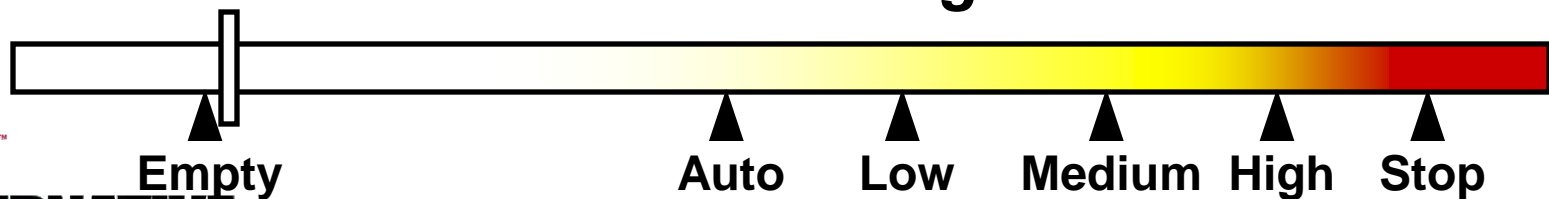

Normal with

<i>Situation</i>	<i>Dash Lamps</i>	<i>Operator Action</i>
<p>Normal Operation</p> <p>Active Regen.</p> <p>Above "Low Speed"</p>	<p>HEST Lamp OFF (OEM dependent)</p>	<p>None</p>



DPF Loading

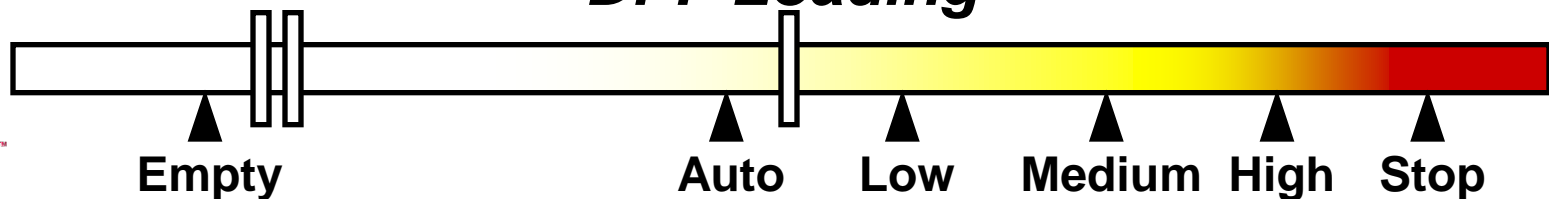

Normal with

<i>Situation</i>	<i>Dash Lamps</i>	<i>Operator Action</i>
Normal Operation Active Regen. Below "Low Speed" Limit	HEST Lamp On	Use Caution

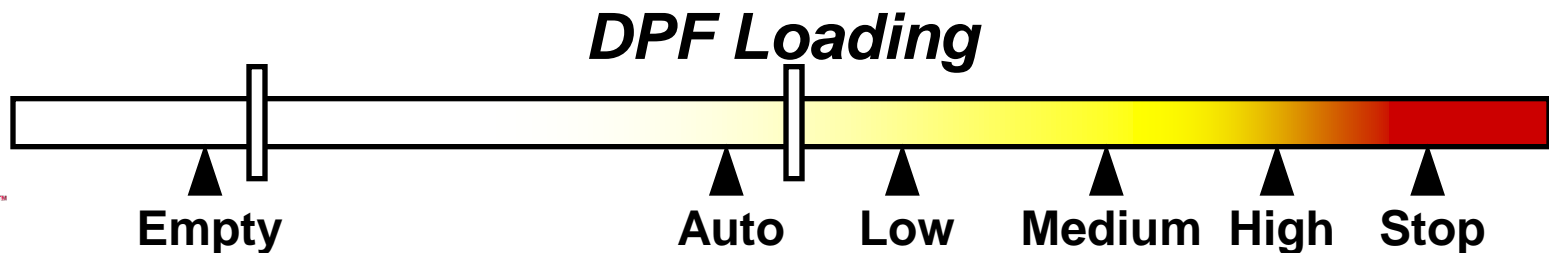
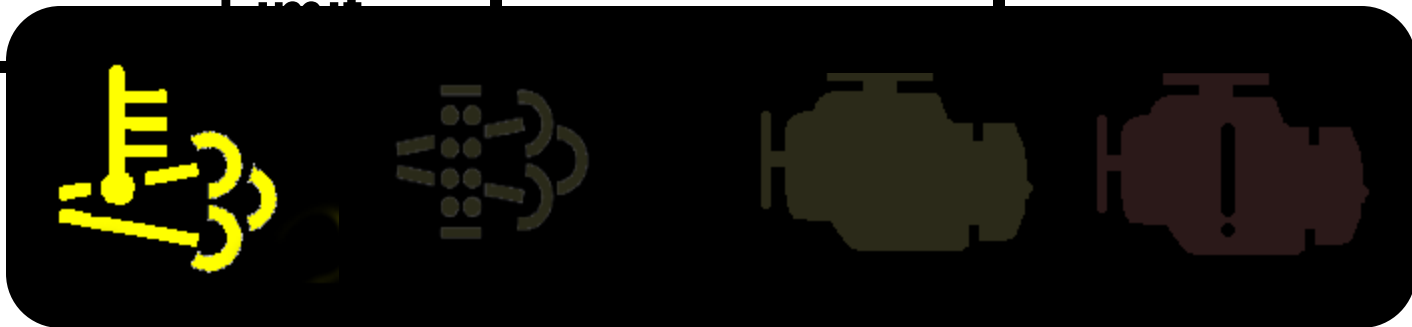

Light Duty Cycle

<i>Situation</i>	<i>Dash Lamps</i>	<i>Operator Action</i>
<p>Light Duty Cycle</p> <p>No Active Regeneration</p>	<p>DPF Lamp on</p>	<p>Regeneration <i>(next 2-6 hours)</i></p> <p>Change Duty Cycle</p>



DPF Loading

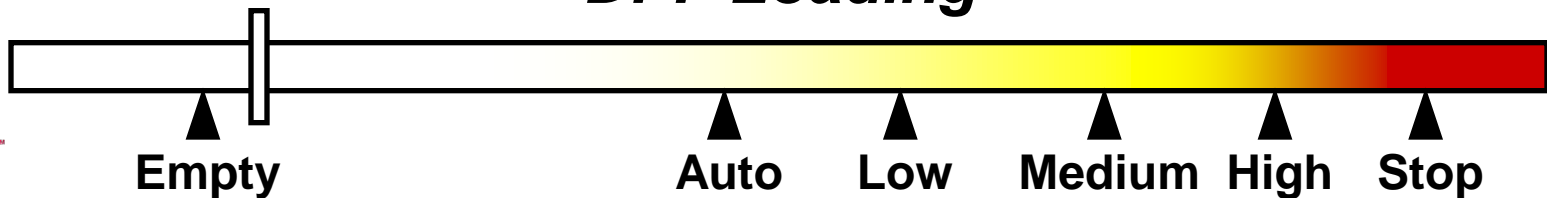

Light Duty Cycle

<i>Situation</i>	<i>Dash Lamps</i>	<i>Operator Action</i>
Light Duty Cycle No Regeneration DPF <u>Moderately</u> Full	DPF Lamp <u>Flashing</u>	Regeneration <i>(next 1-2 hours)</i> Change Duty Cycle

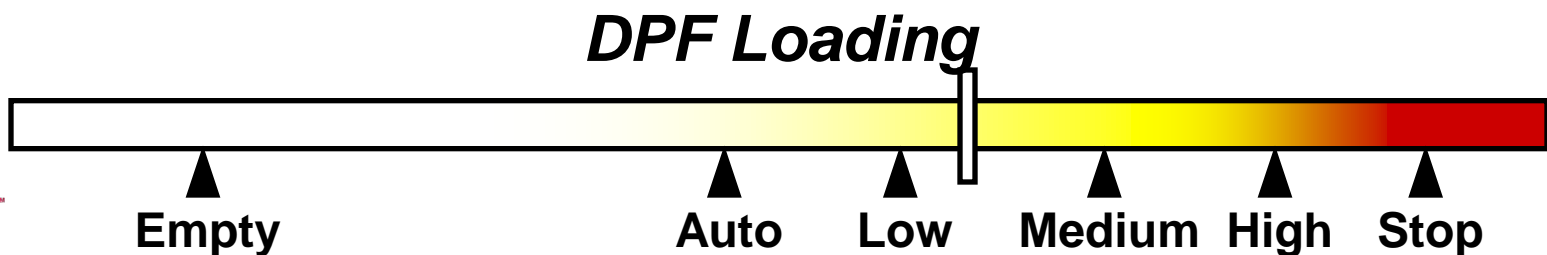

Still No Regeneration

Situation	Dash Lamps	Operator Action
Light Duty Cycle No Regeneration DPF Almost Full Moderate Derate	DPF Lamp Flashing Check Engine	Regeneration Immediately! Change Duty Cycle Parked



DPF Loading

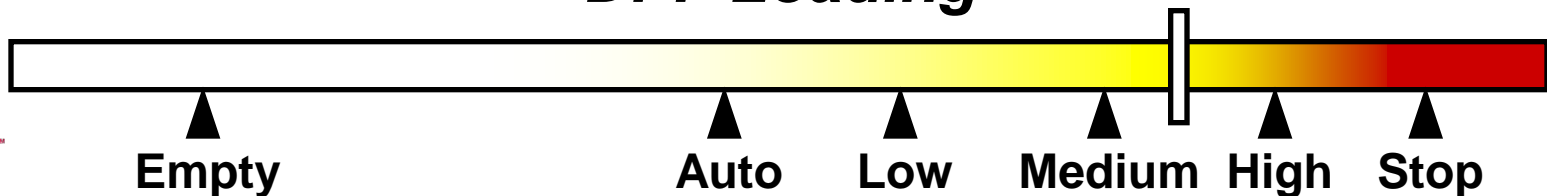

DPF Full

<i>Situation</i>	<i>Dash Lamps</i>	<i>Operator Action</i>
<p>DPF <u>Full</u></p> <p>Severe Derate</p> <p>No</p> <p>Regeneration</p> <p>Allowed</p>	<p>Stop Engine</p> <p>Lamp Comes</p> <p>On</p>	<p>Stop Engine</p> <p>Immediately!</p> <p>Take Vehicle to</p> <p>Authorized Cummins</p>

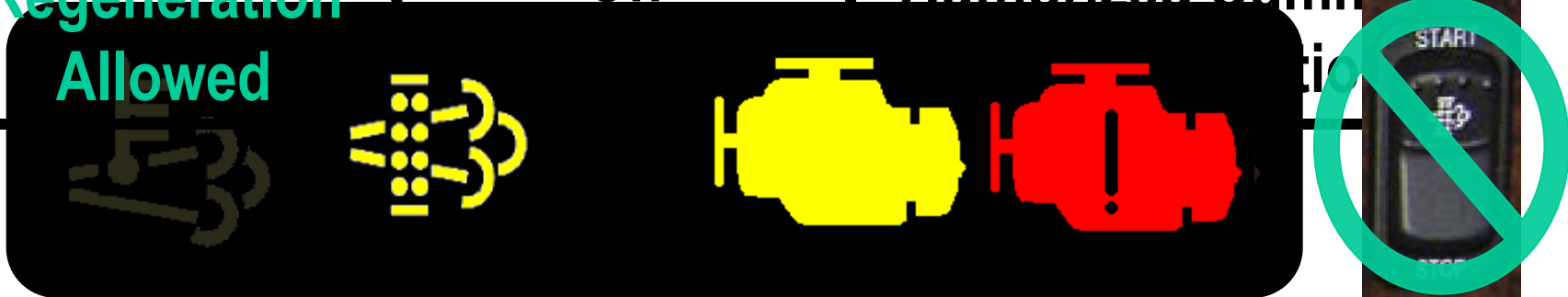

DPF Loading

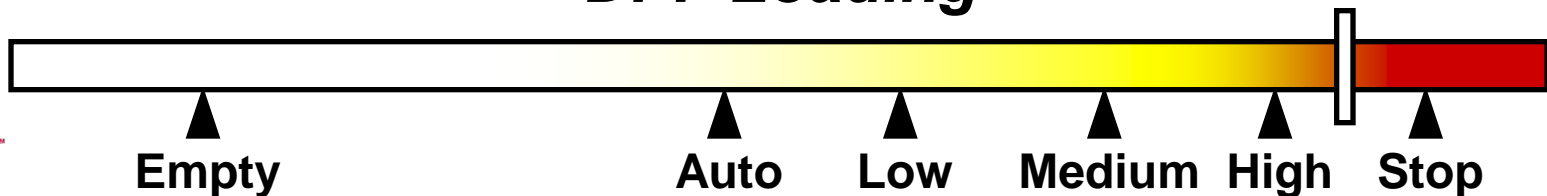



DEPEND ON CUMMINS

EVERYTM MILE.